

Installation Guidance

Heritage Cast Aluminium Gutters & Pipes

Ref: IN001RW

General Advice

Generally

BS 8000 Workmanship on building sites, Part 13, Code of practice for above ground drainage and sanitaryware appliances: 1989 is relevant in general terms.

Handling and Storage

All components should be handled with care to avoid damage and stored on level ground clear of traffic and under cover.

Cutting and Drilling

Gutter and pipe sections can be cut and drilled on site with normal metalworking tools, and holes or slots formed to accommodate fixings. Where powder coated materials are cut it is recommended that exposed edges are painted with a matching enamel touch-up paint (available from Alumasc). Deburr all cut edges.

Gutter Falls

Bracket support: Where possible a fall of 1:600 to 1:350 (maximum) should be allowed for. However gutters can be laid level if this is not possible.

Gutter Fixing

- Outlets and angles should be positioned first, followed by full lengths of gutter, and finally infill lengths cut to fit at the plain end.
- Screw brackets to fascia board at maximum 915mm centres or as recommended by Alumasc for non-standard profiles or special situations. Allow one extra bracket for each angle or outlet.
- Fix brackets so as to position the gutter centrally and as close below the roof edge as possible, taking into consideration locality and roof/slope/finish.
- Use No. 12 x 38mm quality zinc plated, cadmium plated or sherardised twin thread roundhead screw and washer (Countersunk screw for rafter brackets).
- Where high winds are expected, a small bead of sealant must be applied between gutter and bracket as a flexible adhesive.
- An occasional screw, fixed through a slot in the back of the gutter and into the fascia may be preferred, at a minimum of two per length.
- Direct fixing can be used for Victorian Ogee and Moulded gutters, with slots provided as necessary, generally at 600mm centres. When ordering material always specify 'Direct Fix'.

Installation Guidance

Heritage Cast Aluminium Gutters & Pipes

Ref: IN001RW

Gutter Fixing

- Follow specified recommendations for gutter position and laying to falls as above. Use No. 12 x 38mm round head screws as above, but also using aluminium washers to allow for thermal movement.
- A sealing washer shall be used when direct fixing Moulded gutters to prevent leakage through the rear slot in high flow circumstances. Alternatively a small amount of sealant can be applied around the slot and screw head.
- Cast Moulded gutters must be fixed with the sole of the gutter level. This can be achieved by using a continuous batten between the gutter and fascia, or the supplied fixing support bracket at a minimum of two per 1830mm length.
- Always ensure that all fixing slots provided are used. Fixing centres may vary, but always fix at the centre of each slot to allow thermal movement.

Gutter Jointing

- Cast gutters generally overlap at the joint with a spigot and socket.
- Slots are provided for fixing by bolts, nuts and washers to provide support and retention of the union, together with a suitable sealant.
- Thoroughly clean joints and wipe dry. Unpainted cast gutters should be primed (Dow Corning 1200, Feb Primer No. 5).
- Apply sufficient sealant between the gutter and the socket union clip so that some squeezes out of the joint when tightened. A minimum 3mm thickness should be applied right across the joint and around the holes.
- Screws in the sole should be tightened first. Do not overtighten screws.
- Clean off surplus sealant.
- Use M6 mushroom head aluminium screws with aluminium nuts and washers. Available from Alumasc in natural finish only, but matching enamel touch-up paint is available.

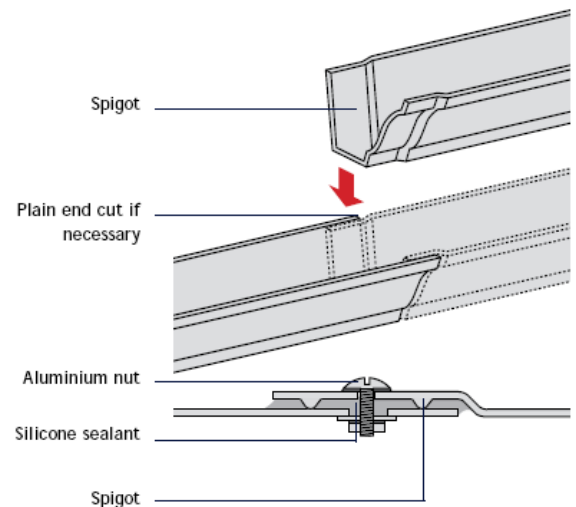

Installation Guidance

Heritage Cast Aluminium Gutters & Pipes

Ref: IN001RW

Downpipe Fixing

- Fix pipe sockets and brackets at 2.0m centres with minimum No. 12 x 50mm round head twin thread screws or similar as above, to plugged walls with a washer beneath the screw head.
- The large hole size is designed to accommodate traditional pipe nail fixing or 6mm minimum proprietary expanding bolts as preferred.

Downpipe Jointing

- Where sockets are supplied separately from the downpipes, these must be lightly driven home onto the pipe, which should be cut square and be free from dents or burrs.
- A light application of low modulus silicone sealant must be applied to both surfaces for a guaranteed waterproof joint.
- Use a block of wood or similar protection at the pipe and socket end to prevent damage when fitting.
- When assembling pipe stacks, allow a 4mm gap between the open end of the top pipe and the flange of the lower socket, to allow thermal movement.
- Pipe and socket joints should be sealed with a low modulus silicone sealant, which will remain flexible. This should be applied over a caulking material such as 6mm polyethylene backing foam, to seal the joint effectively.

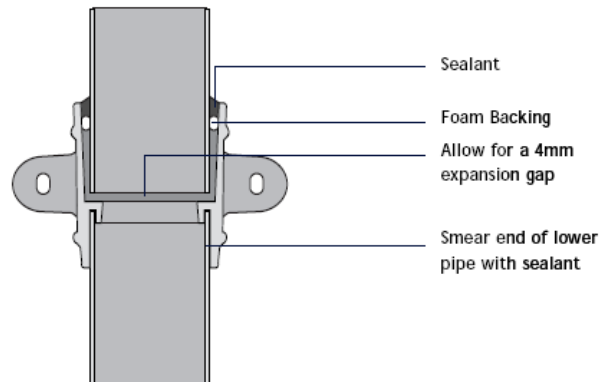

Installation Guidance

Heritage Cast Aluminium Gutters & Pipes

Ref: IN001RW

Site Painting

Degrease with white spirit and clean thoroughly. Prime with zinc phosphate or similar aluminium primer, followed by at least two coats of full gloss paint on all exposed surfaces. Undercoating is not required.

Site Testing

Allow for sufficient curing time of the sealant. The gutter outlet should be plugged, and the gutter filled with water to the overflow level. After 5 minutes the joints should be checked visually for evidence of leaks.