

GUTTER SUPPLIES

PART OF THE PBSL GROUP



U CAST ALUMINIUM OGEE GUTTER INSTALLATION GUIDE

WELCOME TO OUR INSTALLATION GUIDE

Designed to emulate traditional cast iron, our Legacy Cast Aluminium Gutters are manufactured from the highest quality materials and are available in various sizes and profiles.

Our guttering is supplied with a polyester powder coating (PPC), in a textured cast iron effect. The gutters come with a "leatherette" finish, but other colours are available as a special order.

A complete range of accessories, in a traditional style, such as angles, outlets, stop ends and brackets, is available.

BS

BS 460:2002+A2:2007 & BS 8530:2010



NON-COMBUSTIBLE CONSTRUCTION MATERIAL



LOW MAINTENANCE



10

10-YEAR GUARANTEE



60

60-YEAR LIFE EXPECTANCY



ENVIRONMENTALLY FRIENDLY



The Gutter

Cast gutters will often feature the characteristic cast mould and seam imperfections, an aesthetic that is very well suited to traditional and heritage properties.

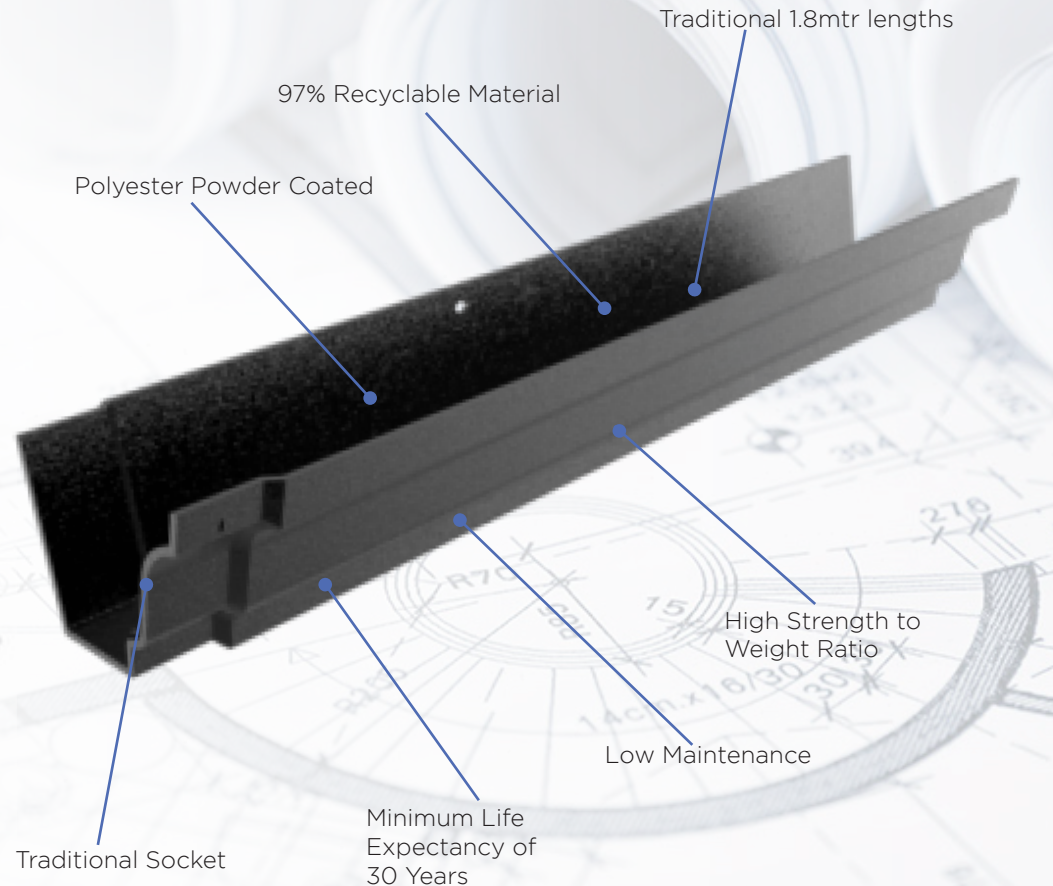

Recycling and Sustainability

Aluminium can be infinitely recycled, only losing less than 3% of its material properties during the recycling process. Recycling also uses 95% less energy than the extraction process! 75% of all aluminium ever produced is still in use today. 92-98% of aluminium from building demolition is recycled.

Accessories

1



Any use of sealant must not be carried out in wet weather or in temperatures below 5°C or above 50°C. All joint surfaces must be perfectly clean and dry. Only a low modulus sealant must be used to prevent early failure. Ensure that the gutter joint sockets/spigots are correctly aligned with each other to ensure free thermal movement (3-4mm) within the gutter joint.

2



Where gutters or pipes are powder-coated, then cut edges should be de-burred and repainted with touch-up paint.

3



It is important that all fixings are suitable for both the substrate and the load. Therefore, they **must** be of the appropriate size and of a compatible material to ensure no electrolytic corrosion occurs. We recommend that stainless steel screws are used.

4



Traditional Gutters are fitted together using M6 x 20mm aluminium nut, bolt & washer.

Setting Out

Gutters may be installed flat (at level) or to a fall of 1:600 (maximum of 1:350) If the surface is flat, make sure that the gutter is set at the correct height at the centre point and use a string line or level to make a series of marks to indicate the correct height along the run length. When trying to achieve a fall the lowest point needs to be the outlet, so mark this position first, followed by the end of the run, and then use a string line to mark regular points of reference.

Cutting and Drilling

Gutter sections may be cut and drilled on-site using standard metalworking tools, however, the use of angle grinders is not recommended. Where gutters or fittings are powder-coated, then cut edges should be de-burred and repainted with touch-up paint (available from PBSL Group).

Handling and Storage

Gutters, downpipes, and fittings, particularly with polyester powder coat, finish should be handled with care and preferably stored under cover on racks to prevent scratching. Whilst not known to pose any health hazard, it is recommended that protective gloves be worn when handling mill finish aluminium.

All lengths are supplied in a protective polythene wrapping with components similarly wrapped and stored in cardboard boxes. If a PPC product is to be stored outside, cover it with a tarpaulin to protect against rainfall and direct sunlight. Failure to do this may allow water to get trapped inside the protective wrapper and could lead to permanent watermarks on the paint finish. Mill finish items should be stored under cover to avoid uneven oxidization before being fitted.

Safety

Personal protection equipment (PPE) should be worn at all times when installing cast aluminium guttering

We recommend to wear gloves, protective eye wear, and a dust mask.



Fig1 The current recommendation from the Metal Gutter Manufacturers Association (MGMA) is to position gutters as Fig 1.

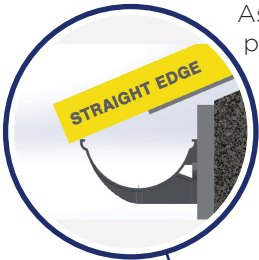

Fig 1 is more resistant to sliding snow than Fig 2.

Fig2 There are certain conditions where a Fig 1 installation might allow water to over shoot the gutter or high wind conditions may allow water to blow behind the gutter.

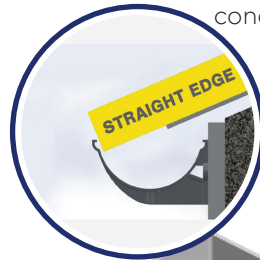
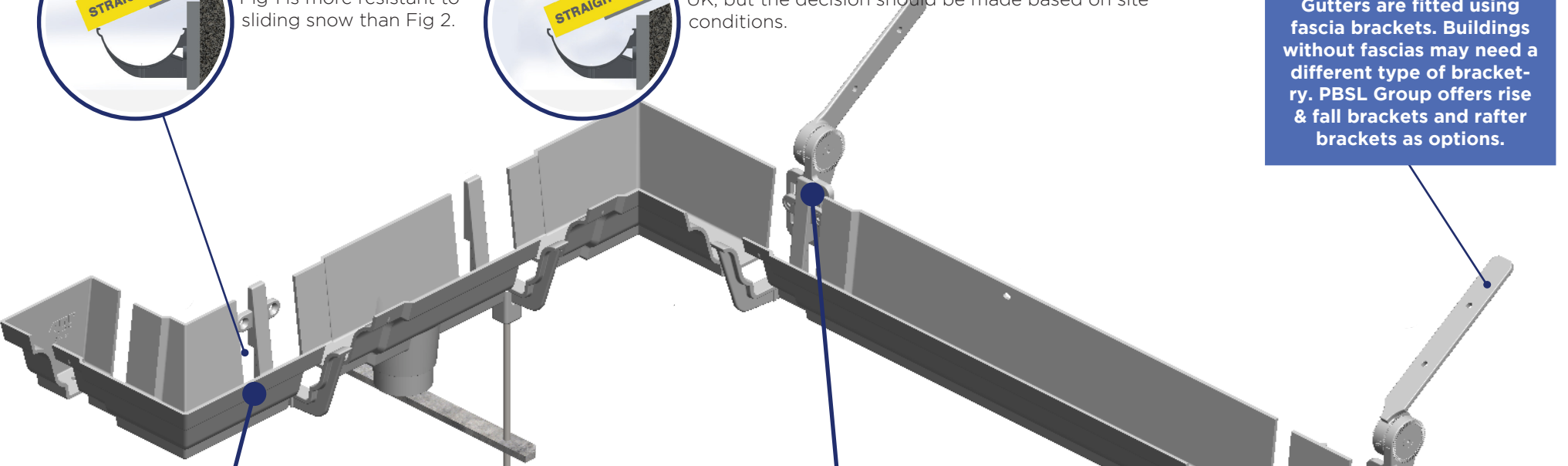
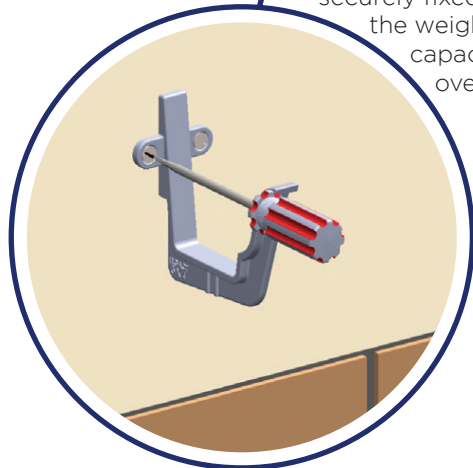

Fig 1 is the preferred option for the majority of the UK, but the decision should be made based on site conditions.

 Legacy Cast Aluminium Gutters are fitted using fascia brackets. Buildings without fascias may need a different type of bracketry. PBSL Group offers rise & fall brackets and rafter brackets as options.





STEP 1 We advise that you ensure the fixing background (e.g. fascia board) is securely fixed, flat and able to support the weight of the gutter at full capacity and that the roof overhang is correct.

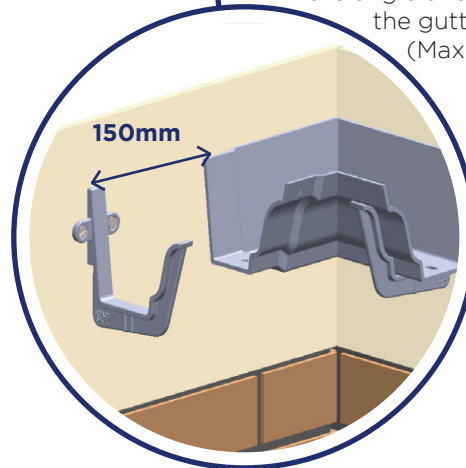

Start by deciding whether to fit the gutter at a level or with a fall to 1:600. Fit a bracket at each end of a run. Position brackets correctly for an angle or stopend.

STEP 2 Image 2 shows the ideal bracket positioning for the angle and bracket to take the gutter length. (Max 150 mm from joint).



 Any cut lengths should be de-burred and touched up with touch-up paint supplied prior to installation.

For more information or further assistance, please contact us.

STEP 3 We recommend fixing brackets every 915mm and using an additional bracket for each outlet or angle.

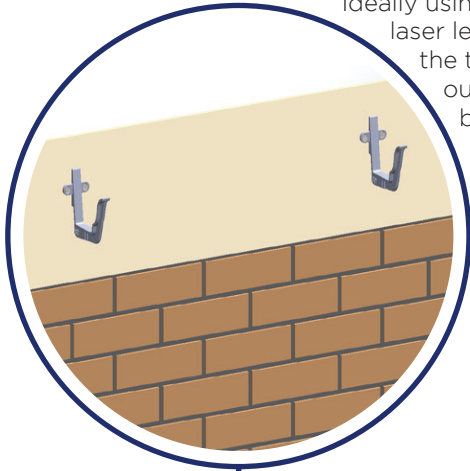

Ideally using a string line or laser level between the two brackets, set out intermediate brackets at maximum centres of 915mm.

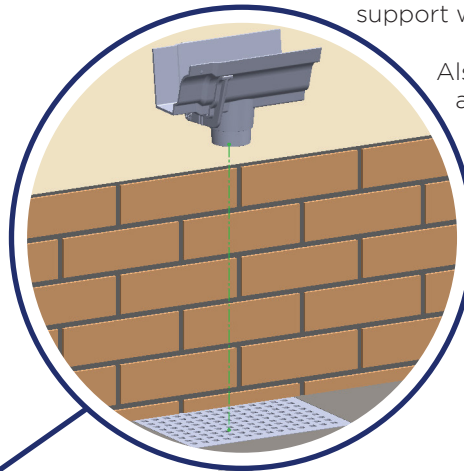

STEP 4 With the use of a plumb or laser line, position outlets over gullies and support with at least one bracket.

Also include a bracket per angle (internal or external).



Moulded Ogee can also be directly fixed with the use of wedges.

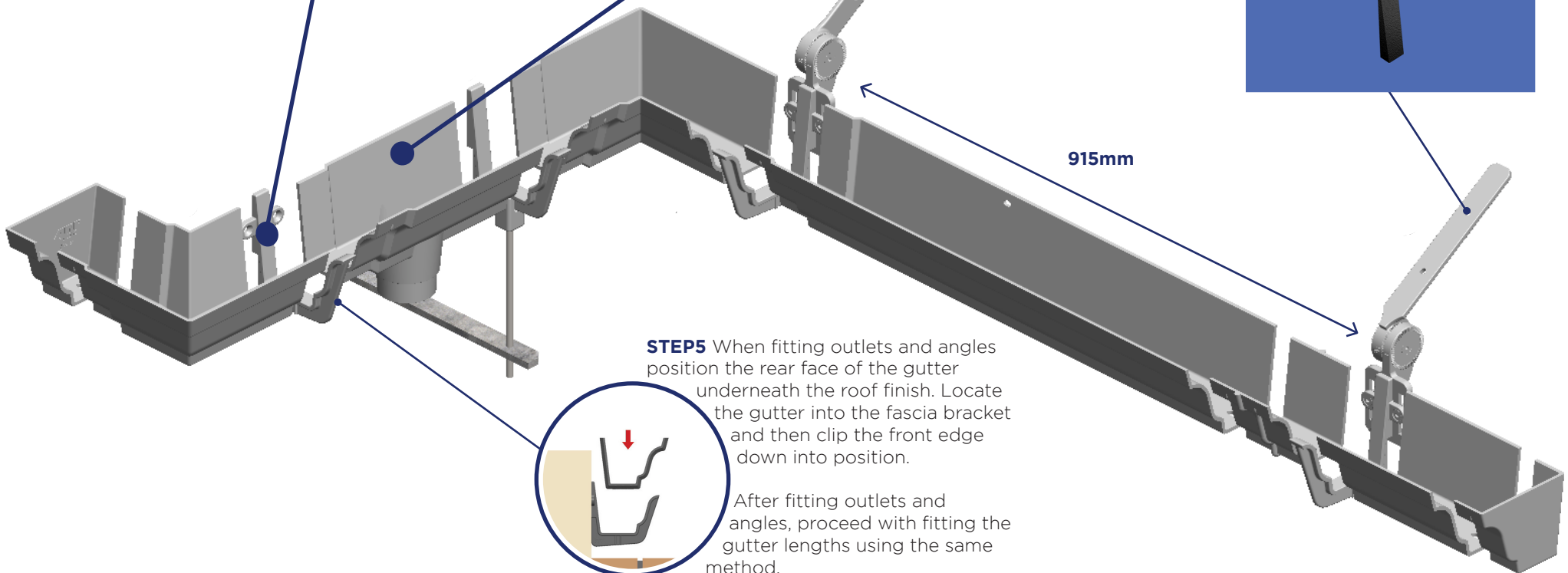

STEPS When fitting outlets and angles position the rear face of the gutter underneath the roof finish. Locate the gutter into the fascia bracket and then clip the front edge down into position.

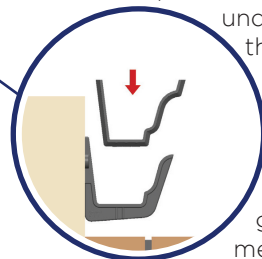

After fitting outlets and angles, proceed with fitting the gutter lengths using the same method.

STEP 6 Ensure that all fixing surfaces are clean and dry.

Apply 2 x 6mm beads of Arbo Low Modulus Sealant into the socket end of gutter. Then place gutter length into sealant/socket.



STEP 7 Push the bolt through the sole of the gutter socket, ensuring that the slot is filled with sealant. Before applying the nut and washer, gently tighten. Do not over-tighten as this may force the sealant out of the joint.

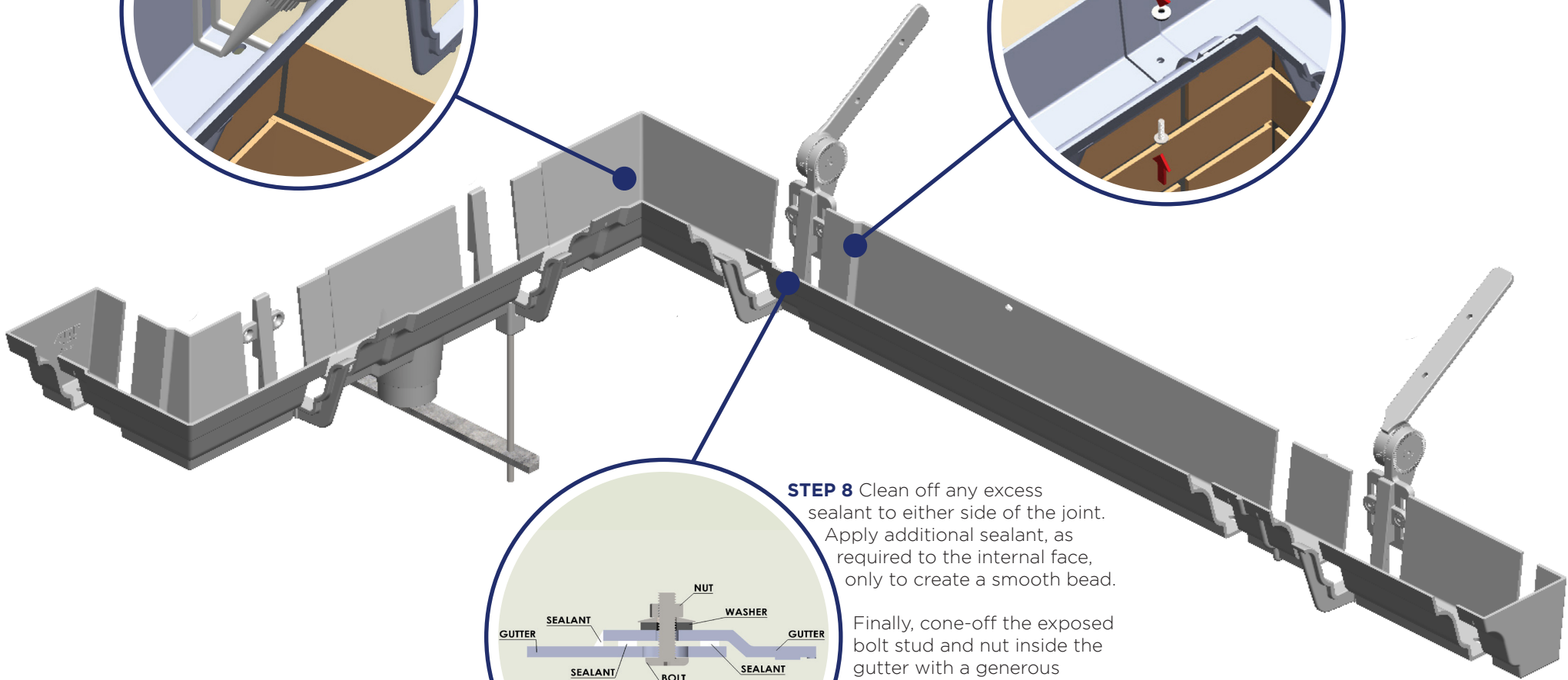
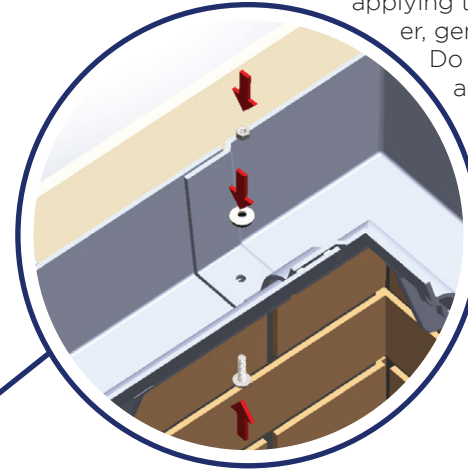

STEP 8 Clean off any excess sealant to either side of the joint. Apply additional sealant, as required to the internal face, only to create a smooth bead.

Finally, cone-off the exposed bolt stud and nut inside the gutter with a generous application of Arbo Low Modulus Sealant. Tool off excess silicone around the joint and from external surfaces.

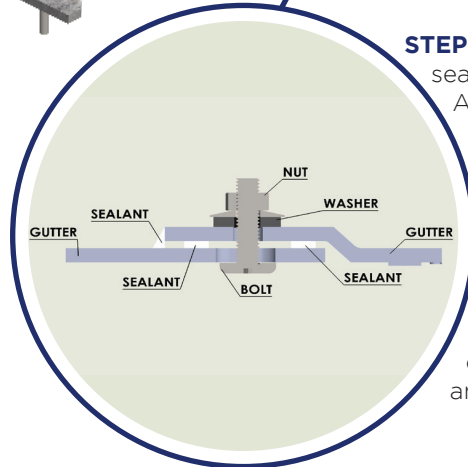

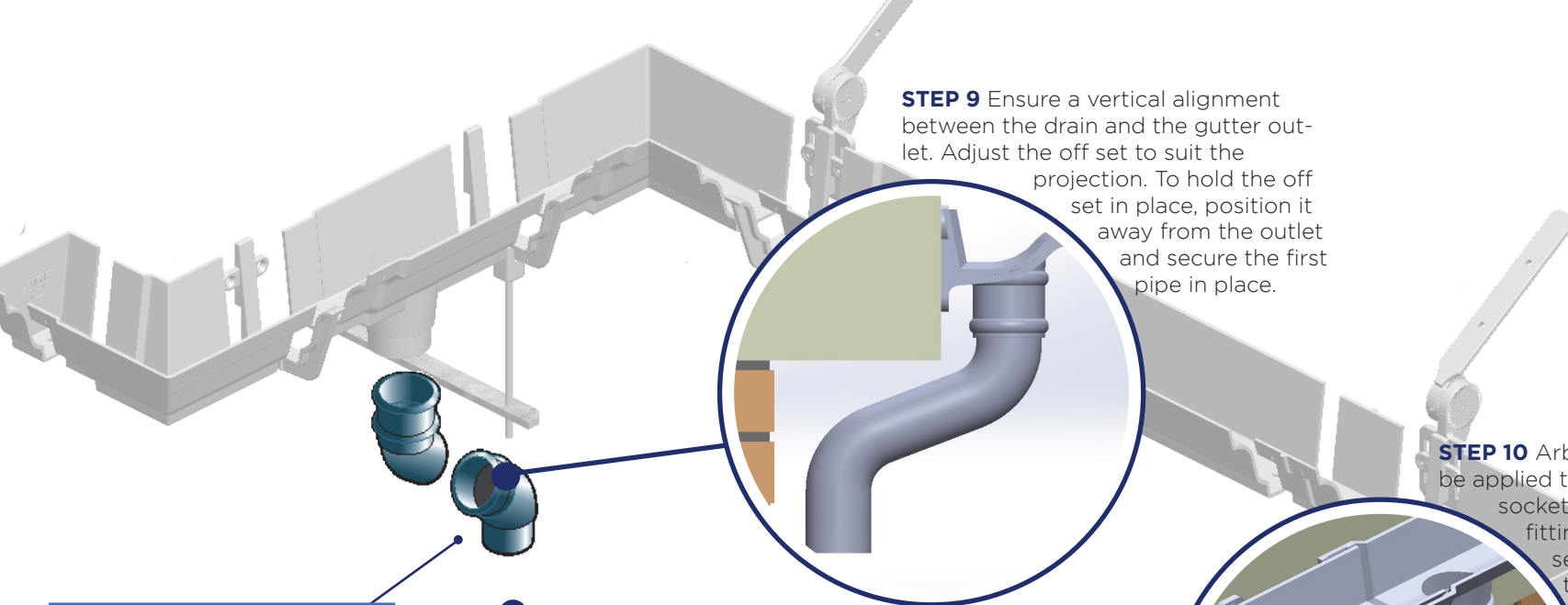

STEP 9 Ensure a vertical alignment between the drain and the gutter outlet. Adjust the off set to suit the projection. To hold the off set in place, position it away from the outlet and secure the first pipe in place.

STEP 10 Arbo Low Modulus Sealant can be applied to the inside of the pipe socket prior to installation. When fitting flushjoint downpipe, sealant can also be applied to the inside of the clip to assist in supporting the pipe. A pipe clip should be fixed directly beneath the pipe socket.

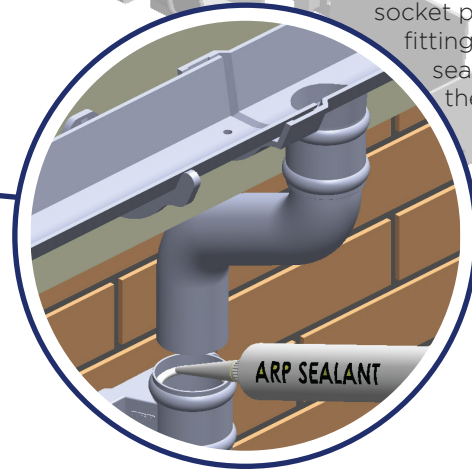

STEP 11 Additional pipe clips should be fitted at 2m maximum intervals.

Any cut lengths should be de-burred and touched up with touch-up paint prior to installation. For more information or further assistance, please contact us.

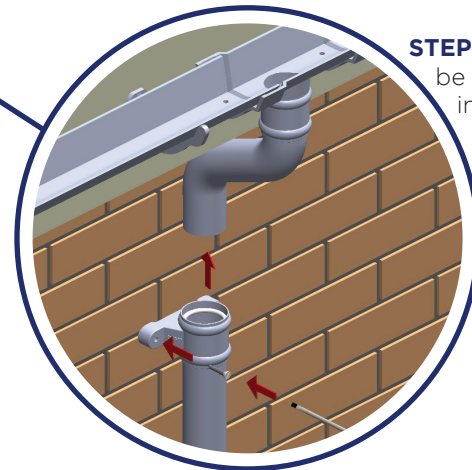

 We advise that you ensure the fixing background is in good condition and will support the downpipe and that there are sufficient clips/brackets in place to secure the load.

When fitting downpipes, start from the outlet and work towards the gully. Make sure you have the right combination of offset bends, branches, and pipes to complete the installation.

Maximum fixing centre is 2 metres using correct stainless steel fixings and plugs for the substrate being fitted to.

For more information or further assistance, please contact us.

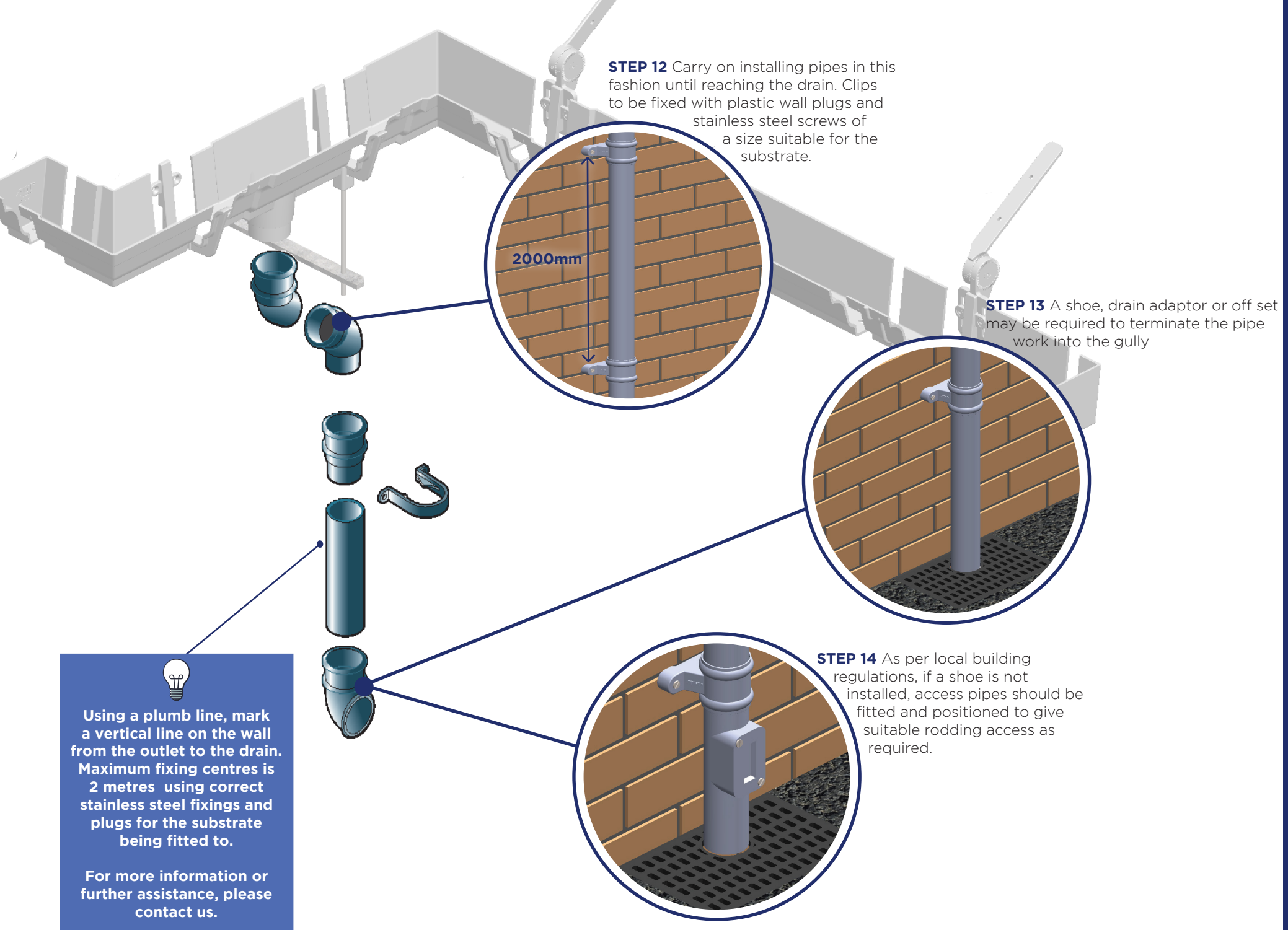

STEP 12 Carry on installing pipes in this fashion until reaching the drain. Clips to be fixed with plastic wall plugs and stainless steel screws of a size suitable for the substrate.

2000mm

STEP 13 A shoe, drain adaptor or off set may be required to terminate the pipe work into the gully

STEP 14 As per local building regulations, if a shoe is not installed, access pipes should be fitted and positioned to give suitable rodding access as required.

 Using a plumb line, mark a vertical line on the wall from the outlet to the drain. Maximum fixing centres is 2 metres using correct stainless steel fixings and plugs for the substrate being fitted to.

For more information or further assistance, please contact us.